



Complies to BS EN 1253-1:2015

**THE ALL NEW**

**MULTIPLE ACCESS  
FLOOR TRAP SYSTEM**

**SMART  
GULLY**

**WORKS  
SMARTER  
& FLOWS  
BETTER**



Print Edition for December 2025

# About Us



## About Us

Sansico Industries Sdn Bhd has established a strong reputation for delivering high-quality products to its customers. Our unwavering commitment to excellence has driven us to continuously invest in research and development, recognizing the significance of offering durable, reliable, and superior products.

In 2008, Sansico™ made a significant breakthrough with the introduction of its top access floor traps, marking a notable milestone in our product portfolio. The remarkable quality and innovation of our SI & S2 models garnered recognition when we received the prestigious new product award at ARCHIDEX 2009, a testament to our dedication to pushing boundaries and setting industry standards.

Building on this success, in 2017 we once again received the new product award at ARCHIDEX 2017 for our ground-breaking patented 360-aligning collar. This innovation showcased our commitment to continuous improvement and our ability to address industry challenges with creative solutions. As a result, our floor trap systems have gained widespread adoption and success in a variety of settings, including condominiums, houses, hospitals, commercial buildings, offices, hypermarkets, and even overseas markets such as Singapore, Indonesia, Thailand, Cambodia, and Vietnam.

Driven by an entrepreneurial spirit, we have revolutionized our floor trap designs to overcome the shortcomings observed in existing top access floor trap systems available in the market. In 2021, we proudly unveiled our state-of-the-art S4 model, which has been granted SIRIM approval—an acknowledgment of its exceptional quality and compliance with industry standards. The S4 model currently boasts an elegant and sleek design and incorporates an innovative feature known as the "Zero Water Seal," effectively addressing the issue of fast water seal drying. With this breakthrough, we have successfully eliminated a common problem encountered in traditional floor trap systems, further enhancing the overall performance and reliability of our products.

In addition to our ground-breaking floor trap systems, Sansico™ takes pride in offering the widest range of locally manufactured, high quality floor gratings available in the market. This comprehensive selection provides unparalleled flexibility and enables architects and designers to create aesthetically pleasing top finishing designs in various building projects.

Through our unwavering commitment to innovation, quality, and customer satisfaction, Sansico™ continues to lead the way in delivering superior products for the construction industry. With each achievement, we reinforce our position as a trusted provider of top-notch solutions that meet the evolving needs and expectations of our valued customers.

# Introduction

Floor gullies, also known as floor drains, are plumbing fixtures designed to collect and drain water from the floor surface. They are commonly used in commercial and residential structures, in areas such as bathrooms, showers, basements, kitchens, and industrial facilities where water or other liquids may accumulate: primarily installed in areas at a heightened risk of water flooding, spillage, foul odours, and vermin infiltration.

Floor gullies play a vital role in safeguarding buildings from flooding and maintaining a hygienic indoor environment. To ensure optimal functionality and prevent blockages and backups, it is imperative to focus on proper installation and easy maintenance of floor gullies.



## SANSICO™

# SMART GULLY



The Sansico™ Smart Gully revolutionizes drainage systems by incorporating a retrievable basket strainer that is an integral part of the system, ensuring easy maintenance and improved flow efficiency. It seamlessly integrates the system into a multiple access, striking a perfect balance for convenient top and bottom maintenance. This ensures that the smart gully consistently operates at its optimal level, guaranteeing reliable functionality at all times.

The revolutionary design of this smart gully not only reduces water turbulence but also increases the flow rate (120 litres per min), allowing efficient and effective removal of wastewater inside buildings. Additionally, it boasts exceptional durability, withstanding various external factors, and offers a higher water seal compared to other gullies available in the market.

Overall, the combination of reduced water turbulence, increased flow rate, durability, resistance to external factors, and higher water seal makes this gully design a highly efficient and reliable choice for wastewater removal inside buildings. This transformation has fundamentally changed the way people think or live.

### OUR GULLIES COMPLY TO BS EN 1253-1:2015 SIRIM STANDARD

BS EN 1253-1:2015 is an important standard for ensuring the quality and performance of floor gullies in buildings. It helps to ensure that floor gullies are safe, reliable, and effective at draining wastewater.

#### SIRIM Test Undertaken

- Access for cleaning
- Thermal Cyclic
- Water tightness
- Odour tightness
- Mechanical strength
- Resistance to water seal
- Flow rate through grating
- Flow rate through inlets

# Material Characteristics



Light Weight



Higher Flow Rate



Higher Water Seal



Chemical Resistant



Corrosion Resistant



Flame Resistant



Impact Strength



Cost Effective



Durable & Reliable



Ozone Resistant (O-Ring)



UV Resistant (O-Ring)



Less Turbulent

## Technical Data

### BENEFITS

It has been aesthetically re-engineered to enhance the following benefits:

- Less turbulence
- Higher flow rate **120 litres/min**
- Better sealing mechanism with **EPDM gasket** (excellent UV/Ozone, chemical & heat resistant)
- Higher water seal **52.5mm**
- More inlets for better wastewater management
- Multiple access for easy maintenance
- SIRIM certified (BS EN 1253-1:2015 compliance)

### Sectional & Exploded 3D View



# Fluid Flow Simulation

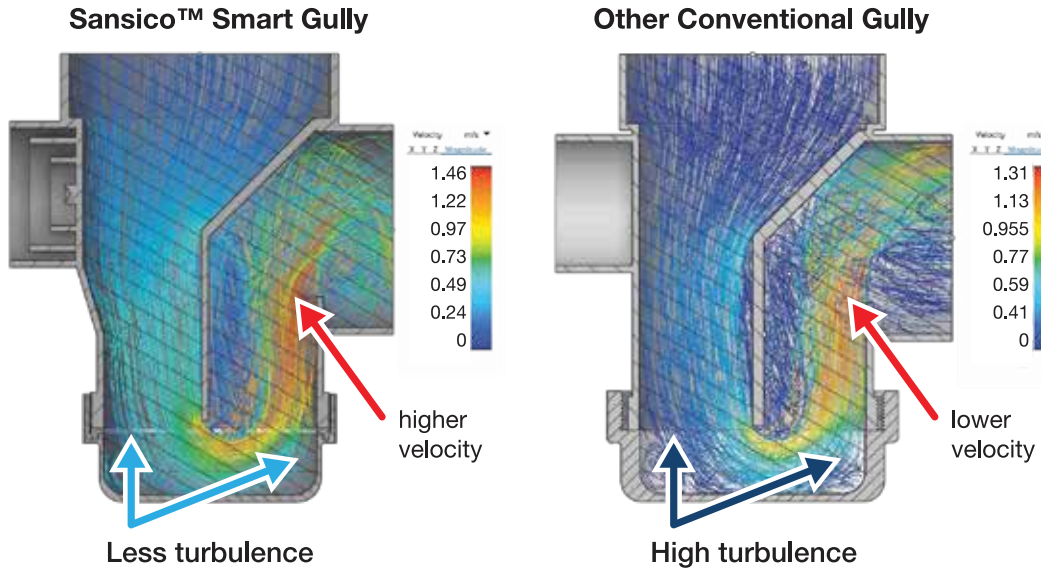

# Installation Drawings

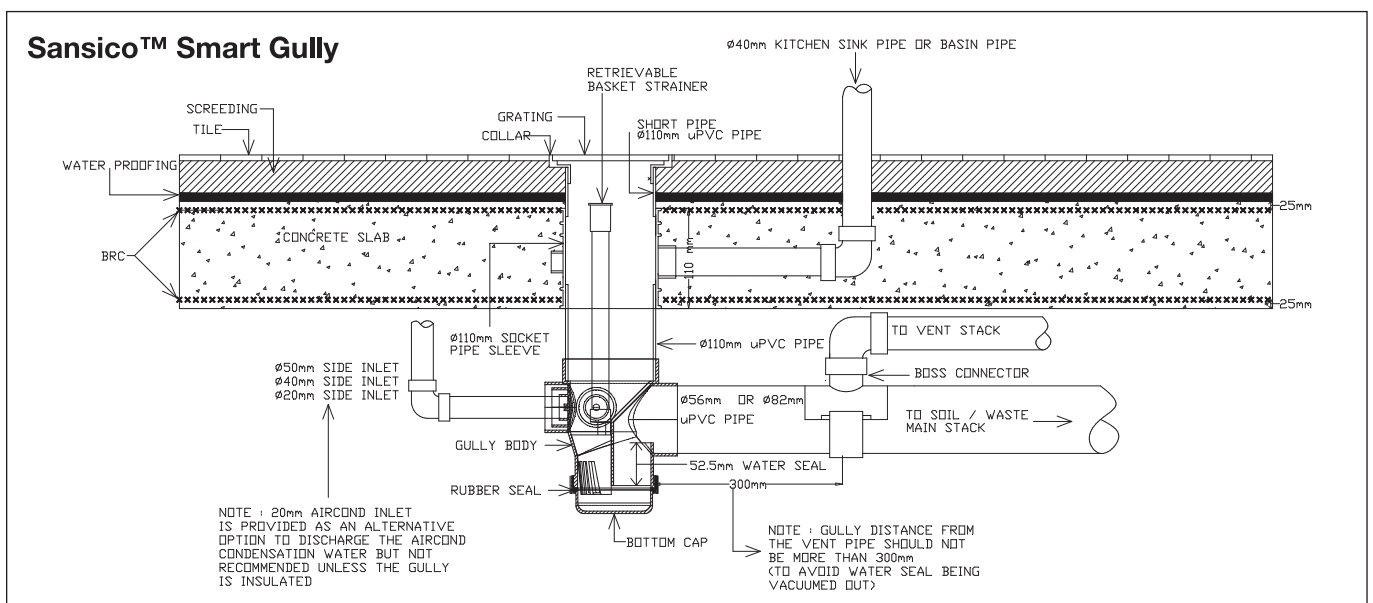
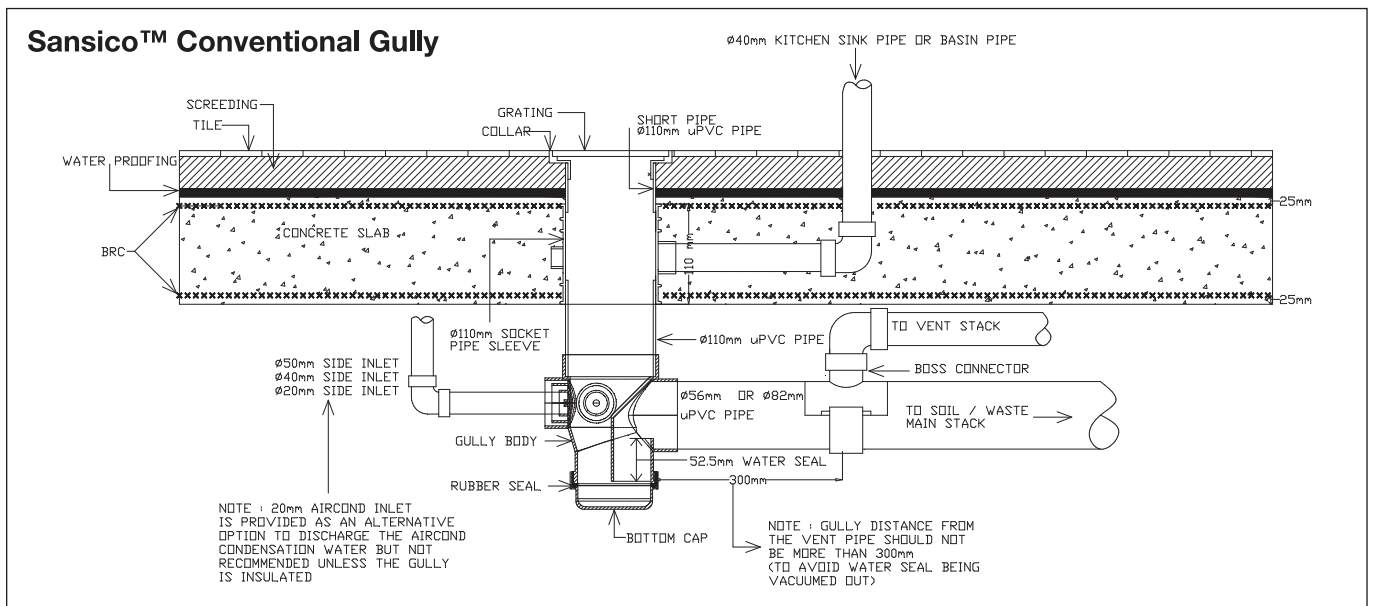

# Dimensions & Product Codes

## Sansico™ Conventional Gullies

Flow rate : 120 litres/min

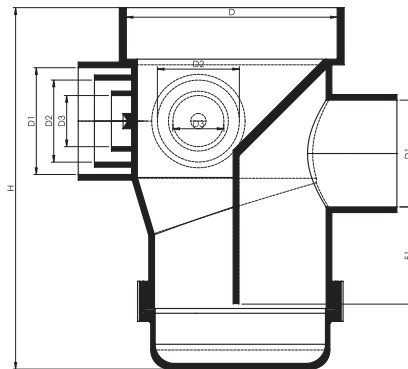

110mm X 56mm

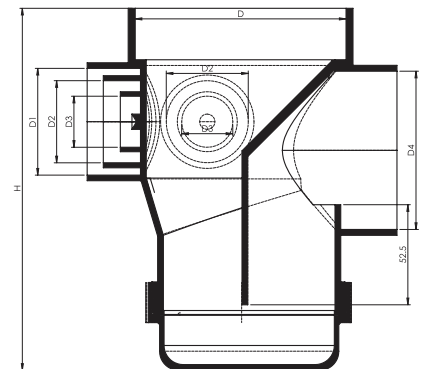

110mm X 82mm

Product Code	Nominal Size (mm)	Dimension					
		D	D1	D2	D3	D4	H
S-FGIO-110X56	110 X 56	110.15	55.95	42.95	26.75	-	190.25
S-FGIO-110X82	110 X 82	110.15	55.95	42.95	26.75	82.60	190.25

## Sansico™ Smart Gullies

Flow rate : 115 litres/min

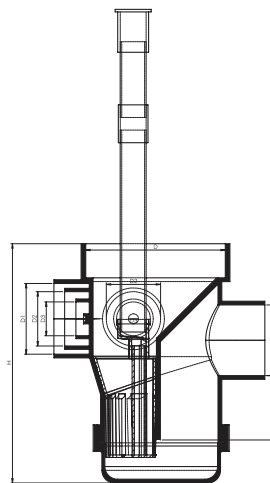

110mm X 56mm

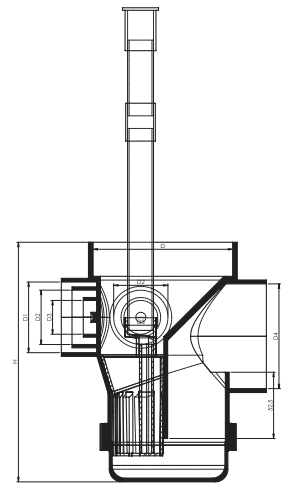

110mm X 82mm

Product Code	Nominal Size (mm)	Dimension					
		D	D1	D2	D3	D4	H
S-SGIO-110X56	110 X 56	110.15	55.95	42.95	26.75	-	190.25
S-SGIO-110X82	110 X 82	110.15	55.95	42.95	26.75	82.60	190.25

## Retrievable Basket Strainer

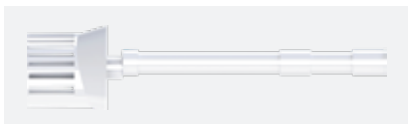

Product Code

SSG-RBS



**We recommend using our Sansico floor gratings together with the Sansico Multiple Access Floor Trap System to ensure full compatibility.  
View our floor grating options here:**



*Scan to download the  
Grating & Collar Catalogue*

**SANSICO**<sup>SM</sup>

**HANSEN**<sup>TM</sup>

**Sansico Industries Sdn Bhd** (448766-D)

No. 20, Jalan Uranus AK U5/AK,  
Taman Subang Impian, Seksyen U5,  
40150 Shah Alam, Selangor.

---

Tel : (603) 7859 7299 (Hunting Line)

Fax : (603) 7859 0299

E-mail : [enquiry@sansico.com.my](mailto:enquiry@sansico.com.my)

Website : [www.sansico.com.my](http://www.sansico.com.my)